

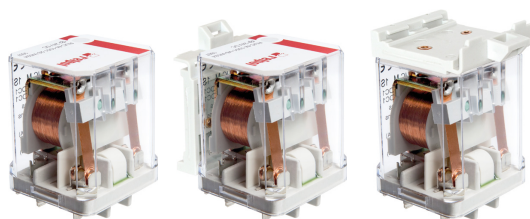



RUC-M

industrial relays for DC loads



with adaptor (V)

with adaptor (H)

- Relays with permanent magnet whose magnetic field blows the electric arc between the contacts; for high DC loads
- AC and DC coils, insulation class F: 155 °C • For plug-in sockets: on 35 mm rail mount acc. to EN 60715; on panel mounting • Versions: PCB; faston 187 (4,8 x 0,5 mm) • Contact gap: 3 mm (version 2 NO); 6 mm (version 1 NO) • Additional features: L - light indicator (LED)
- Applications: control of electromagnets; systems of heating, cooling, ventilation, air conditioning; control with single-phase motors; catering industry machines and equipment; automation systems; photoelectric systems; etc.
- Recognitions, certifications, directives: RoHS,   

Contact data

Number and type of contacts		1 NO (double-break)	2 NO
Contact material		AgNi, AgSnO₂	
Rated / max. switching voltage		250 V DC; 250 V AC / 350 V DC; 440 V AC 	
Min. switching voltage		5 V AgNi, 10 V AgSnO ₂	
Rated load	DC1	16 A / 24 V DC; 14 A / 110 V DC	16 A / 24 V DC; 10,5 A / 110 V DC
	DC L/R=40 ms	12 A / 220 V DC	4,5 A / 220 V DC
	AC1	16 A / 24 V DC; 5,4 A / 110 V DC	16 A / 24 V DC; 1,35 A / 110 V DC
		3 A / 220 V DC	0,45 A / 220 V DC
		16 A / 250 V AC	16 A / 250 V AC
Min. switching current		5 mA AgNi, 10 mA AgSnO ₂	
Max. inrush current		40 A 20 ms	
Rated current		16 A	
Max. breaking capacity	AC1	4 000 VA	
Min. breaking capacity		0,3 W AgNi, 1 W AgSnO ₂	
Contact resistance		≤ 100 mΩ	
Max. operating frequency		1 200 cycles/hour	
• at rated load	AC1	12 000 cycles/hour	
• no load			

Coil data

Rated voltage	50/60 Hz AC	12, 24, 48, 115, 120, 230, 240 V
	DC	12, 24, 48, 110, 220 V reinforced coil
Must release voltage		AC: ≥ 0,15 U _n DC: ≥ 0,1 U _n
Operating range of supply voltage		AC: 0,85...1,1 U _n DC: 0,8...1,1 U _n see Tables 1, 2
Rated power consumption	AC	2,8 VA
	DC	1,7 W

Insulation according to EN 60664-1

Insulation rated voltage	400 V AC
Rated surge voltage	4 000 V 1,2 / 50 μs
Overvoltage category	III
Insulation pollution degree	3
Dielectric strength	
• between coil and contacts	2 500 V AC type of insulation: basic
• contact clearance	4 000 V AC contact 1 NO, type of clearance: full-disconnection
	2 000 V AC contacts 2 NO, type of clearance: full-disconnection
• pole - pole	2 500 V AC contacts 2 NO, type of insulation: basic
Contact - coil distance	
• clearance	≥ 6,3 mm
• creepage	≥ 8 mm

The data in bold type relate to the standard versions of the relays.  For RUC-M with GUC11S-V0 socket, max. switching voltages and coil voltages of relays are limited to 250 V AC / DC.

RUC-M

industrial relays for DC loads

General data

Operating / release time (typical values)	20 ms / 15 ms	
Electrical life		
• resistive DC1	> 2 x 10 ⁵	contact 1 NO, 12 A, 220 V DC
	> 2 x 10 ⁵	contacts 2 NO, 4,5 A, 220 V DC
• DC L/R=40 ms	> 2 x 10 ⁵	contact 1 NO, 3 A, 220 V DC
	> 2 x 10 ⁵	contacts 2 NO, 0,45 A, 220 V DC
Mechanical life (cycles)	> 2 x 10 ⁷	
Dimensions (L x W x H) / Weight	36,1 x 38,6 x 45,5 mm / 80 g for plug-in sockets 36,1 x 38,6 x 52,5 mm / 80 g for PCB 58,75 x 38,6 x 45,9 mm / 85 g with adaptor (V) 46,8 x 38,6 x 62,45 mm / 85 g with adaptor (H) 66,3 x 38,6 x 36,1 mm / 85 g with mounting flange	
Ambient temperature (non-condensation and/or icing)	• storage	-40...+85 °C
	• operating	-40...+70 °C
Cover protection category	IP 00 EN 60529	
Shock resistance	10 g	
Vibration resistance	5 g 10...150 Hz	
Solder bath temperature	max. 270 °C	
Soldering time	max. 5 s	

Dimensions - plug-in version (standard)

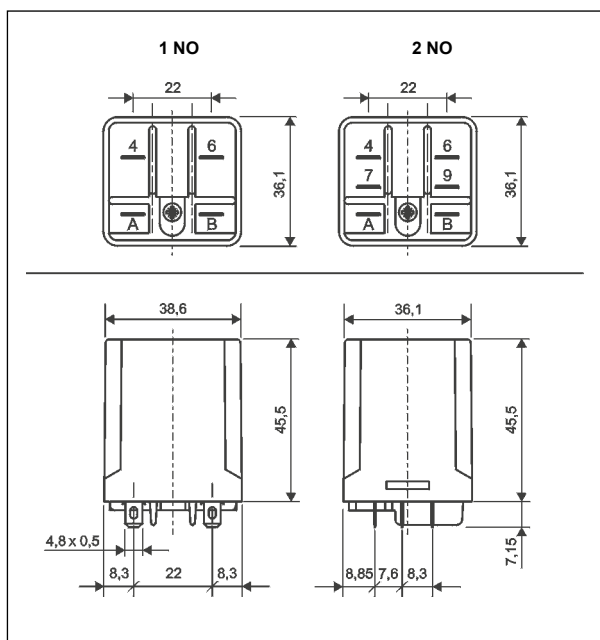

Dimensions - PCB version

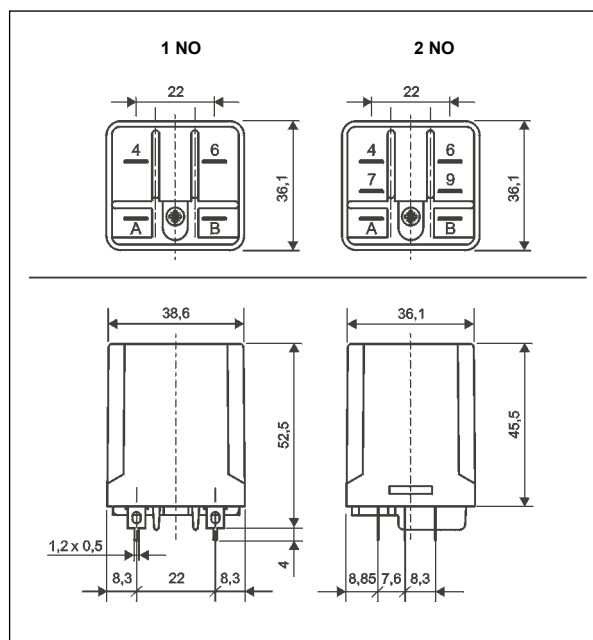

RUCT-M, PRUCT-M

Relays for
railroad industry
- see
www.repol.com.pl

NEW

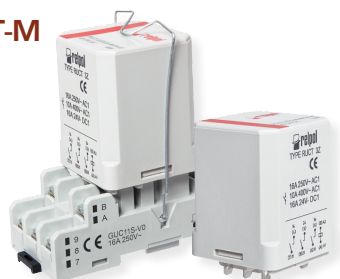

Dimensions - version with vertical adaptor (V)

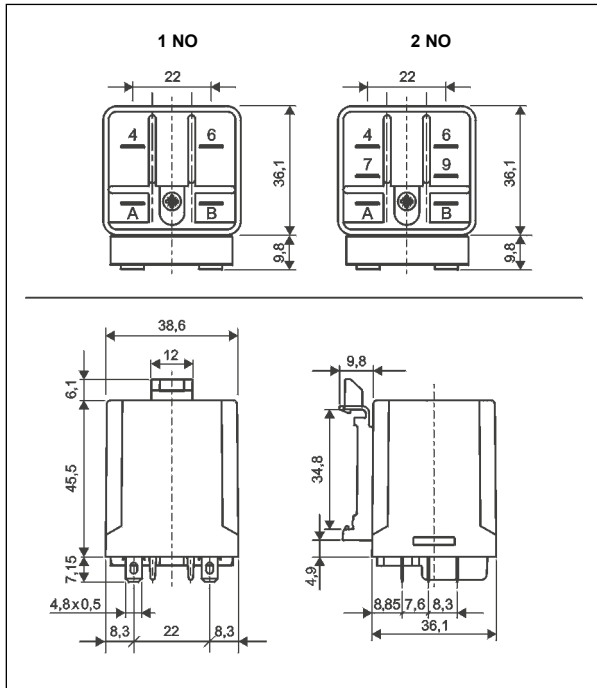

Dimensions - version with horizontal adaptor (H)

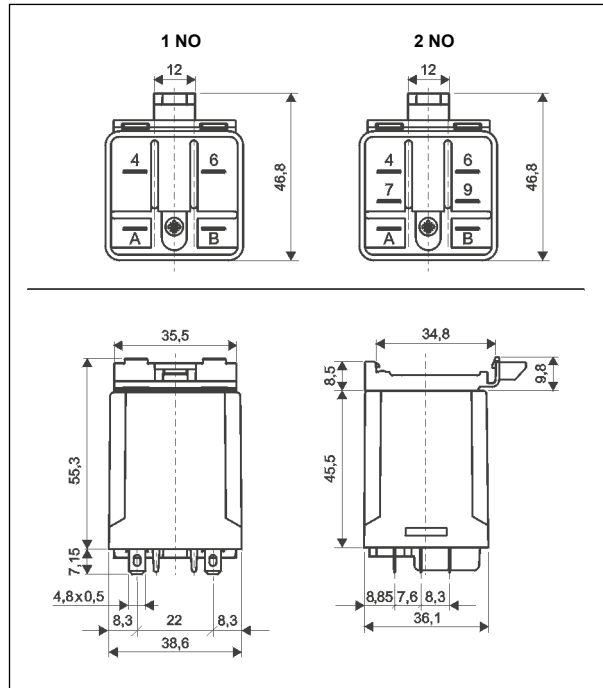

Dimensions - version with mounting flange in the wall of the cover

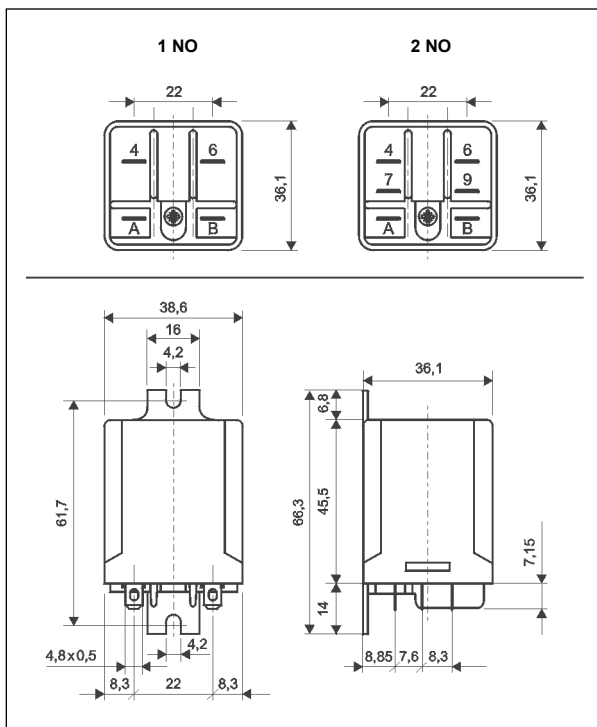

Connection diagrams (pin side view)

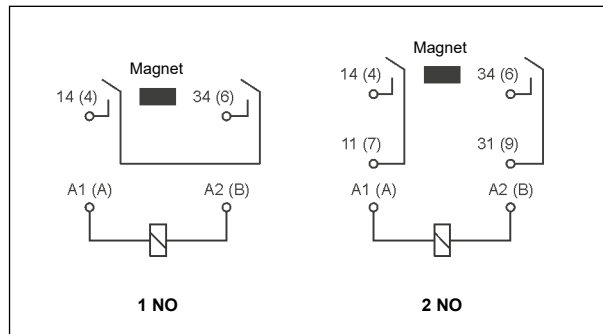

Design

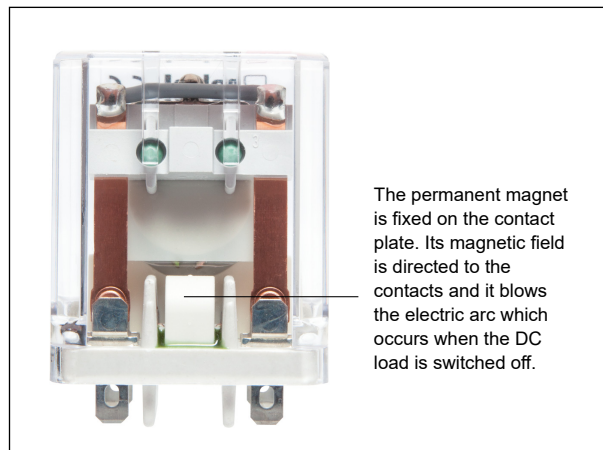

Electrical life at AC resistive load.
Switching frequency: 1 200 cycles/hour

Fig. 1

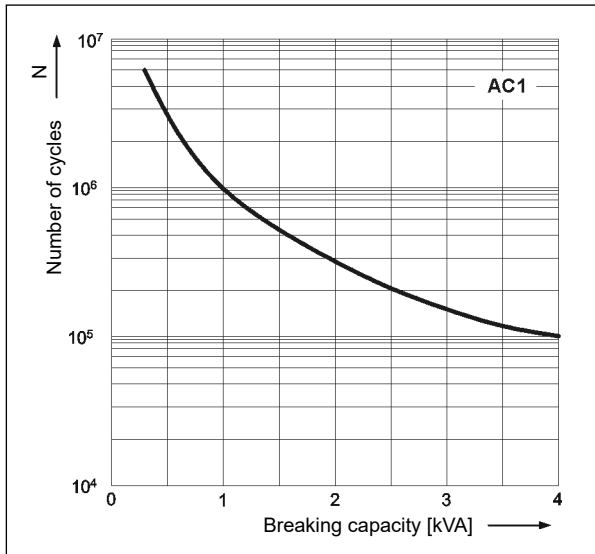

Electrical life reduction factor at AC inductive load

Fig. 2

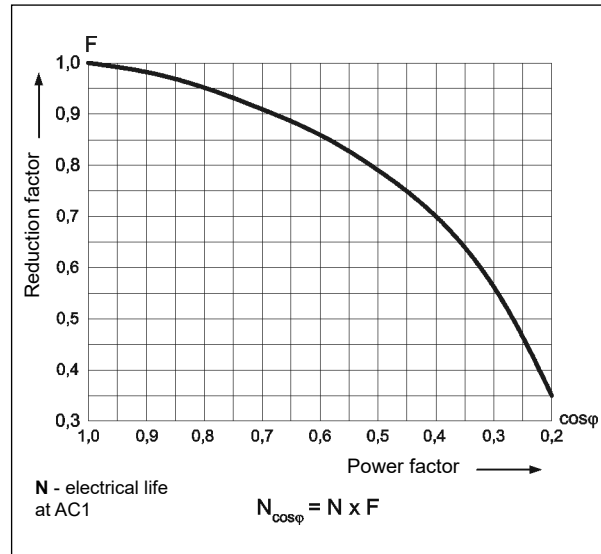

Max. DC breaking capacity
A - resistive load DC1
B - inductive load L/R = 40 ms
 $U_n = 24 \text{ V DC}$ - version 1 NO (6 mm)

Fig. 3

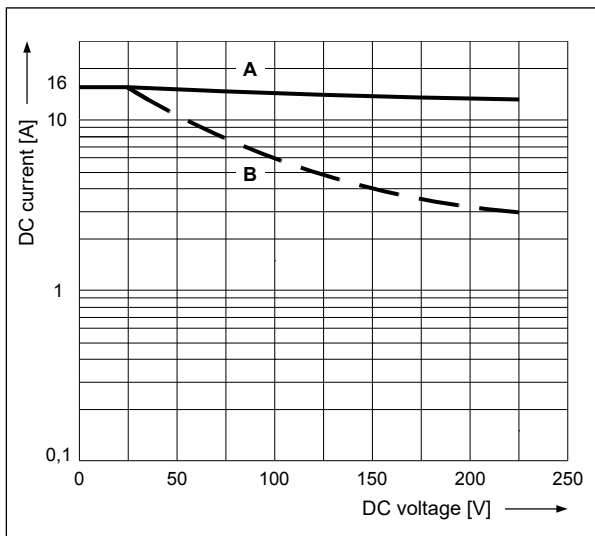

Max. DC breaking capacity
A - resistive load DC1
B - inductive load L/R = 40 ms
 $U_n = 24 \text{ V DC}$ - version 2 NO (3 mm)

Fig. 4

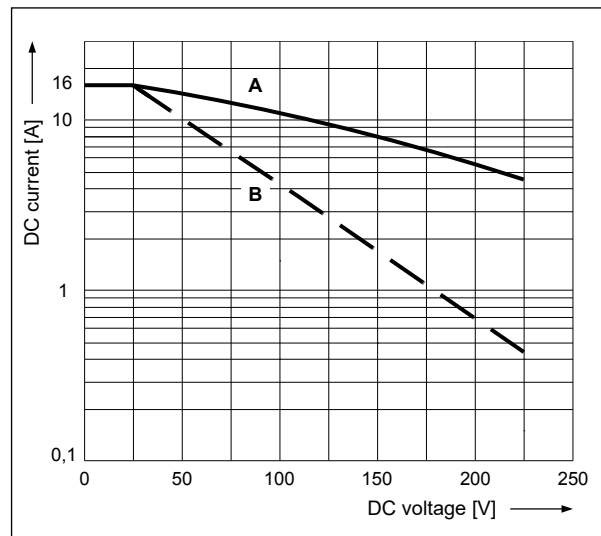

Mounting, sockets and accessories for relays

Relays **RUC-M** are offered in versions: • standard, for plug-in sockets • with mounting flange in the wall of the cover, on panel mounting with two M4 screws, flat insert connectors - faston 187 (4,8 x 0,5 mm) • with vertical (V) or horizontal (H) adaptors for direct mounting on 35 mm rail mount acc. to EN 60715, flat insert connectors - faston 187 (4,8 x 0,5 mm) • for direct PCB mounting ☉.

Sockets for RUC-M	Accessories
	Spring wire clips
Screw terminals sockets, 35 mm rail mount (EN 60715)	
GUC11S-V0 ☉	MBA

☉ For RUC-M with GUC11S-V0 socket, max. switching voltages and coil voltages of relays are limited to 250 V AC / DC. ☉ Relays unavailable with (V) or (H) adaptor, and cover with mounting flange.

Coil data - DC voltage version, reinforced

Table 1

Coil code	Rated voltage V DC	Coil resistance at 20 °C Ω	Acceptable resistance	Coil operating range V DC	
				min. (at 20 °C)	max. (at 70 °C)
W012	12	85	± 10%	9,6	13,2
W024	24	345	± 10%	19,2	26,4
W048	48	1 370	± 10%	38,4	52,8
W110	110	7 300	± 10%	88,0	121,0
W220	220	30 000	± 10%	176,0	242,0

Coil data - AC 50/60 Hz voltage version

Table 2

Coil code	Rated voltage V AC	Coil resistance at 20 °C Ω	Acceptable resistance	Coil operating range V AC	
				min. (at 20 °C)	max. (at 55 °C)
5012	12	18,5	± 15%	9,6	13,2
5024	24	75	± 15%	19,2	26,4
5048	48	305	± 15%	38,4	52,8
5115	115	1 840	± 15%	92,0	126,5
5120	120	1 910	± 15%	96,0	132,0
5230	230	7 080	± 15%	184,0	253,0
5240	240	7 760	± 15%	192,0	264,0

Ordering codes

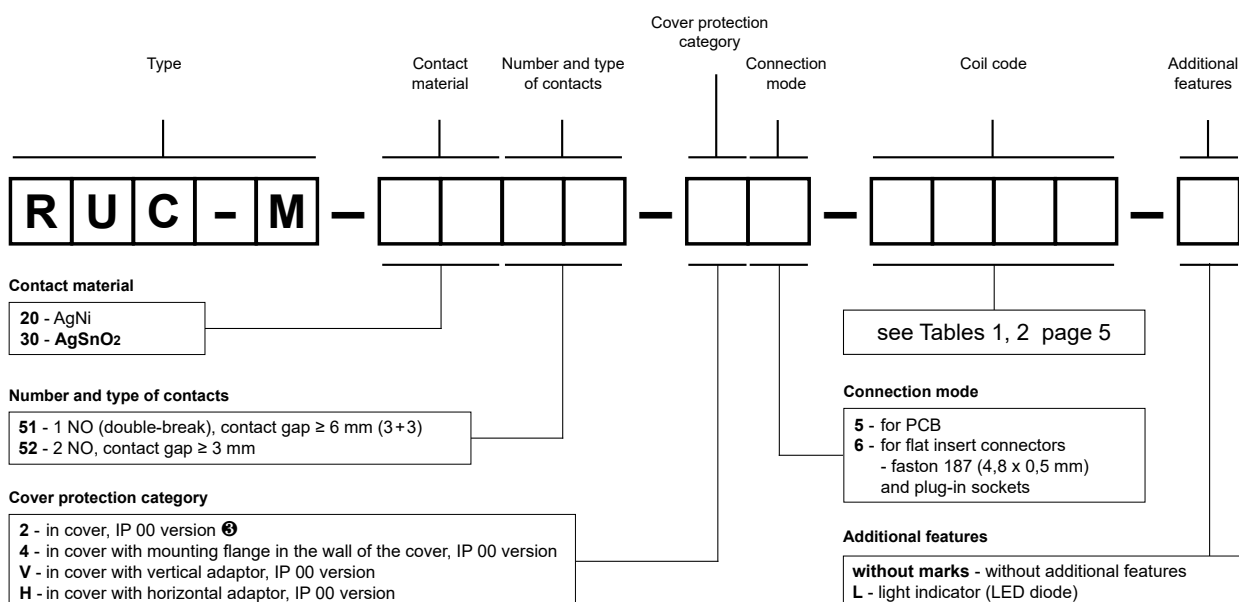

[Ⓢ] For relays RUC-M: for plug-in sockets; for PCB.

Examples of ordering codes:

RUC-M-3051-26-W024 relay **RUC-M**, faston 187 (4,8 x 0,5 mm), with contact gap ≥ 6 mm (3+3), for plug-in sockets, one normally open contact (double-break), contact material AgSnO₂, reinforced coil voltage 24 V DC, in cover IP 00

RUC-M-2052-V6-5230-L relay **RUC-M**, faston 187 (4,8 x 0,5 mm), for flat insert connectors, with contact gap ≥ 3 mm, with vertical adaptor (V), two normally open contacts, contact material AgNi, coil voltage 230 V AC 50/60 Hz, with light indicator (LED diode), in cover IP 00

RUC-M-2051-25-5024 relay **RUC-M**, with contact gap ≥ 6 mm (3+3), for PCB, one normally open contact (double-break), contact material AgNi, coil voltage 24 V AC 50/60 Hz, in cover IP 00

Plug-in sockets and accessories

GUC11S-V0 ①

For RUC faston 4,8x0,5, RUC-M

Screw terminals

Cross section of the cables: max. $1 \times 4 \text{ mm}^2$
/ $2 \times 2,5 \text{ mm}^2$ (1 x 12 / 2 x 14 AWG),
min. $1 \times 0,25 \text{ mm}^2$ (1 x 23 AWG)

Max. tightening moment
for the terminal: 0,7 Nm

35 mm rail mount

acc. to EN 60715

81,5 x 35,5 x 26,5 mm

Three poles

16 A, 250 V AC



Connection diagram

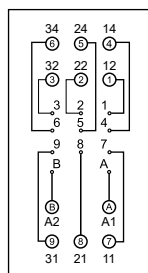

Accessories

MBA

Dimensions

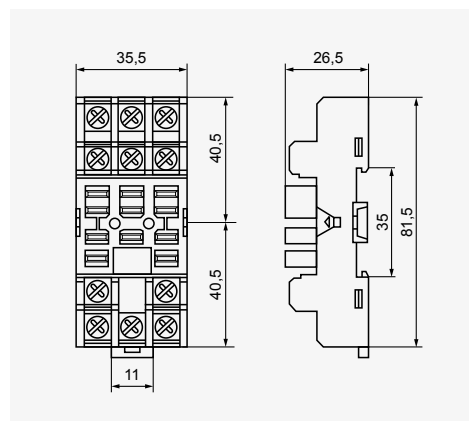

① For RUC faston 4,8 x 0,5 and RUC-M, with GUC11S-V0 socket, max. switching voltages and coil voltages of relays are limited to 250 V AC / DC.

GUC11S-V0

Screw terminals
plug-in sockets for
RUC faston 4,8 x 0,5,
RUC-M

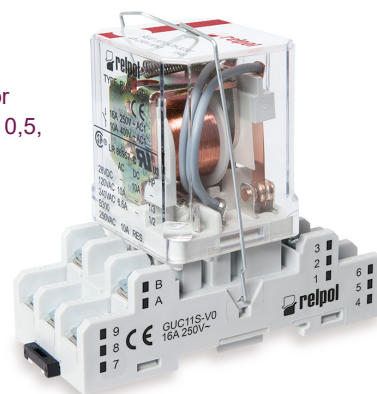

PRECAUTIONS:

1. Ensure that the parameters of the product described in its specification provide a safety margin for the appropriate operation of the device or system and never use the product in circumstances which exceed the parameters of the product. 2. Never touch any live parts of the device. 3. Ensure that the product has been connected correctly. An incorrect connection may cause malfunction, excessive heating or risk of fire. 4. In case of any risk of any serious material loss or death or injuries of humans or animals, the devices or systems shall be designed so to equip them with double safety system to guarantee their reliable operation.