

EXO 5TH

EXO-series plug-in output relay for hazardous locations

Main features

- Solid state output relay for hazardous locations
- Non-sparking device, type of protection nA
- cULus Listed HazLoc, ATEX, IECEx, CE (EMC and LVD)
- Integrated status LED
- For static AC-loads

Functional block diagram

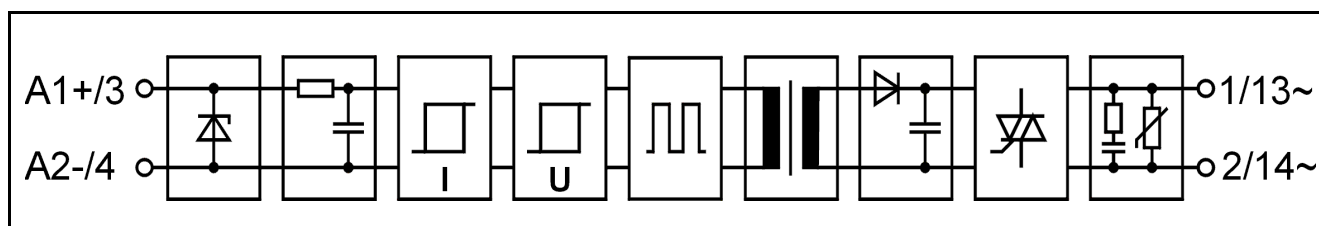

Main specifications

| | | | |
|----------------------------|---------|--|---------|
| Breakdown voltage I/O | minimum | 4300 | VAC rms |
| Air/creepage distances I/O | minimum | 8 | mm |
| Capacitance I/O | typical | 3 | pF |
| Material of the casing | PBT | UL 94V-0 (Sabic Innovative Plastics, Valox 420SEO) | |
| Colour of the casing | | Gray | |
| Weight | typical | 40 | g |
| Temperature range: | | | |
| Storage | range | -40...+70 | °C |
| Operation | range | -10...+70 | °C |

Electrical specifications ($T_A = 25\text{ °C}$)

| Primary | | | | Secondary | | | |
|----------------------------------|---------|-----|-----|--------------------------------|---------|-------|------------|
| Input voltage | nominal | 5 | VDC | Load voltage | nominal | 240 | VAC |
| Input current at nominal voltage | typical | 12 | mA | Load current | maximum | 3 | A |
| | maximum | 15 | mA | Load current | maximum | 90 | A (20 ms) |
| Switch-on voltage | typical | 2,7 | VDC | Voltage drop | typical | 1 | VAC |
| | maximum | 3 | VDC | Switch-on delay | typical | 0,5 | ms |
| Switch-off voltage | typical | 2,5 | VDC | | maximum | 1 | ms |
| | minimum | 2 | VDC | Switch-off delay | typical | - | ms |
| | | | | | maximum | 11 | ms |
| | | | | Load power factor, $\cos \Phi$ | | 0...1 | |
| | | | | dv/dt, off-state | typical | 200 | V/ μ s |
| | | | | Leakage current (off-state) | typical | 1,5 | mA |

Ambient temperature (T_A) means the temperature immediate in vicinity of relays, where the air flow meets the relays.

Deratings

Allowed load is derated to 1/3 linearly from +30 °C to +70 °C ambient temperature. When relays are mounted together as a bank, the load current should be restricted to 66 % of the maximum current. There should be also a gap in both sides at least 12,5 mm. In side by side assembly the load current should be restricted to 33 % of the maximum current. These deratings apply to the horizontal rail assembly and also in vertical rail assembly.

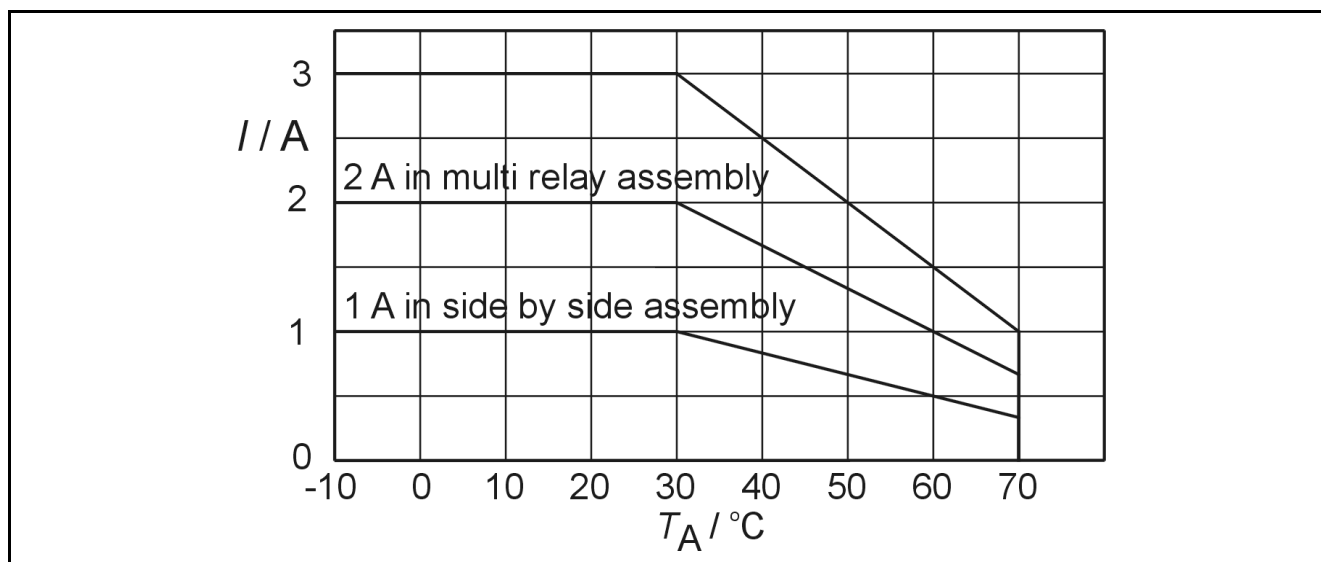

Derating curve for EXO 5TH.

Derating when switching inductive loads

There is no need to derate solid state output relay using a triac switch. The relay is indifferent to the power factor of the load. Calculation should be made however that the surge current does not exceed the specification. For reasons of heat dissipation, when the load will be switched frequently, the average current over a reasonable time should not exceed the specification for continuous operation.

Fusing

To protect relay against short circuit and overload a fast fuse with the correct rating for the load and the capacity of the relay should be chosen. Note that when overload current is not large it is possible that the fuse will not protect the relay because of the tolerance on the fuse rating.

Hazardous area installation

The Solid State Relays shall be installed in accordance with the ATEX directive 94/9/EC and this specification. The relay shall be installed within a suitable certified enclosure providing protection from impact, light, solid foreign objects and water ingress to a level of at least IP54. The relay shall be derated in accordance with this specification.

The relay shall only be installed to mounting sockets MOS 1EX, MOS 1NEX, MOS 1GEX, MOS 1GNEX, MOS 1CCEX, MOS 1CCNEX, MOS 1TEX and MOS 1TNEX. Fixing with the captive screw. The recommended installation is to the horizontal rail for better cooling of the relays.

Assembling in non-hazardous locations

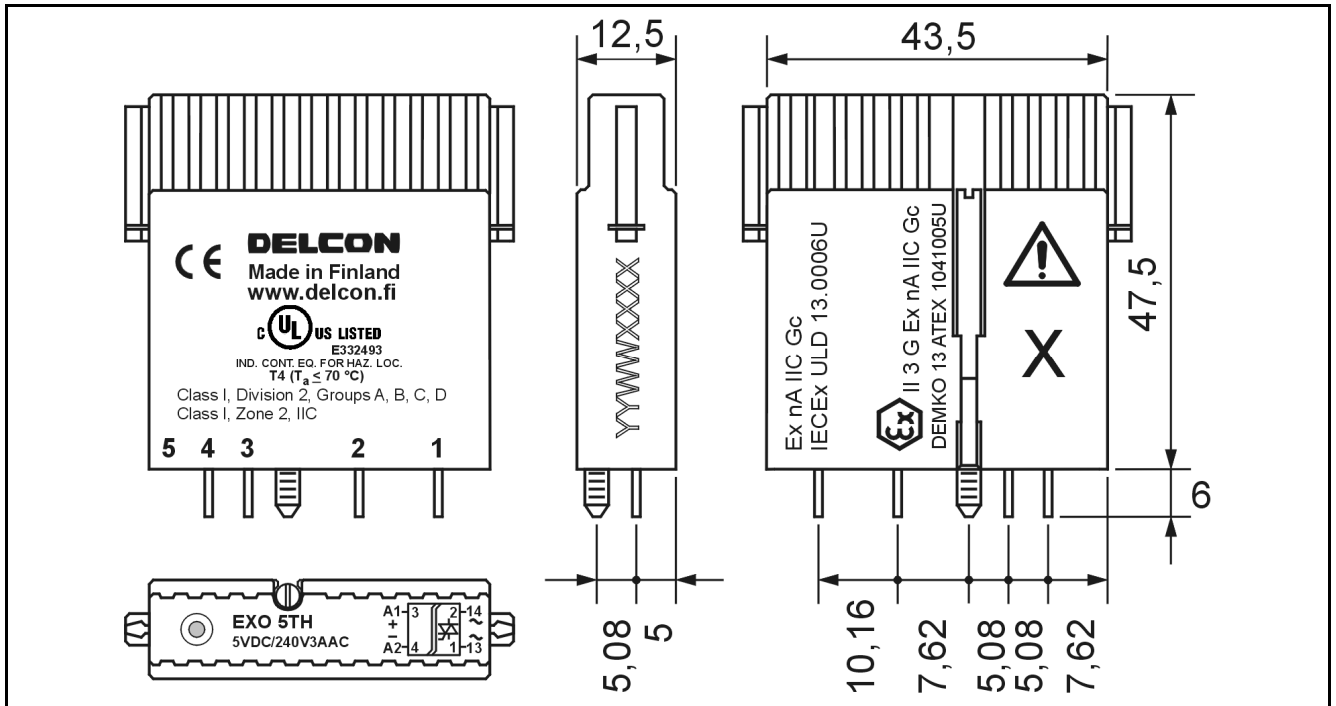

All MOS 1... -mounting sockets, all MB/MBS 8/16... -mounting bases. See the assembly instructions from SL-relay specifications.

Mechanical dimensions



EXO 5TH (dimensions in mm, nominal). Markings can be located differently by production lot. Production lot number is marked to the relay (YY = year, WW = week, XXXX = lot number).

Approvals

| | |
|---|---|
|  IND. CONT. EQ. FOR HAZ. LOC. | Class I, Division 2, Groups A, B, C, D Class I, Zone 2, IIC (when assembled to Ex-approved Delcon mounting socket) Certificate: E332493 |
| ATEX |  II 3G Ex nA IIC Gc (when assembled to Ex-approved Delcon mounting socket) Certificate: DEMKO 13 ATEX 1041005U |
| IECEX | Ex nA IIC Gc (when assembled to Ex-approved Delcon mounting socket) Certificate: IECEX ULD 13.0006U |
|  | Fulfills main requirements of the EMC-directive 2004/108/EC. Fulfills requirements of the low voltage directive (LVD) 2006/95/EC. |

Standards for Ex-approvals:

IEC 60079-0 - ELECTRICAL APPARATUS FOR EXPLOSIVE GAS ATMOSPHERES. PART 0: GENERAL REQUIREMENTS - Edition 5 - Revision Date 2010/12/01

IEC 60079-15 - 2010-01 Edition: 4. Electrical apparatus for explosive gas atmospheres. Part 15: Construction, test and Marking of Type of Protection "n" electrical apparatus

CENELEC EN 60079-0 2009.08.01 Explosive atmospheres - Part 0: Equipment - General requirements

CENELEC EN 60079-15 2010.05.01 Explosive atmospheres - Part 15: Equipment protection by type of protection "n"

CSA C22.2 NO. 213 - NON-INCENDIVE ELECTRICAL EQUIPMENT FOR USE IN CLASS I, DIVISION 2 HAZARDOUS LOCATIONS (1987 EDITION) - Edition 1 - Issue Date 1987/03/01

ISA 12.12.01 - NONINCENDIVE ELECTRICAL EQUIPMENT FOR USE IN CLASS I AND II, DIVISION 2, AND CLASS III, DIVISIONS 1 AND 2 HAZARDOUS (CLASSIFIED) LOCATIONS – Issue date 2011-08-08

Guarantee

This Ex -solid state I/O relay type made by Delcon Oy is guaranteed free from design and manufacturing defects for a period of 10 years from the manufacturing date. The guarantee liability is limited to replacement of defective material and related shipping charges. Defective products must be returned to the manufacturer for evaluation. This guarantee does not cover damage due to incorrect use or electrical overload.